



RDM4024C-PCI Laser Marking Control System

Electrical User Manual

Shenzhen RuiDa Technology CO., LTD

Tel: 86- 0755-26066687

Fax: 86-0755-26982287

Web: www.rd-ac.com

E-Mail: support@rd-ac.com

Add: 1B-1, Building 5, Tian'an Nanyou Industry Area,
Dengliang Road, Nanshan District, Shenzhen, P.R.C.



CONTENTS

CONTENTS	2
Copyright Declaration	3
Chapter 1 Overview	4
1.1 Brief Introduction	4
1.2 Laser Vibrating Mirror Motion Controller Models and Definitions	4
1.3 Laser Vibrating Mirror Motion Controller Functions.....	5
1.4 Basic Components of Laser Vision Marking System.....	6
Chapter 2 Installation & Operation	7
2.1 List of products.....	7
2.2 Controller Configuration	7
2.3 System Installation & Application Steps.....	9
2.4 Terminal.....	13

Copyright Declaration

Shenzhen Ruida Technology Co., Ltd. (hereinafter referred to as “Ruida Technology”)

All rights reserved.

1. Ruida Technology holds the patent rights, copyrights and other intellectual property rights for this product and its related software. Without authorization, none company or organization or individual is allowed to copy, manufacture, process and use this product and its relative parts directly or indirectly, otherwise shall be investigated for legal responsibility according to the law.
2. Ruida Technology is entitled to increase or reduce and modify the products and functions of this product stated herein as well as amend any documents attached to this product, without prior notification.
3. The users should peruse this manual prior to using the product stated herein, Ruida Technology shall not be responsible for the direct, indirect, special, incidental or corresponding losses or damages arising out of improper use hereof or of this product as below:
 - Users using this manual or product improperly
 - Users not follow the related safety operation rules
 - The loss caused by the forces of nature
4. The machine in operation is dangerous, so the users are obliged to design and institute the effective mechanism for error handling and safety protection. Ruida Technology shall not undertake any duties or responsibilities for the incidental or corresponding losses arising therefrom.

Chapter 1 Electrical Manual

1.1 Brief Introduction

The marking controller RDM4024C-PCI based on PCI interface is dedicated for vibrating mirror head real-time control and laser control, which has hardware platform with high performance floating point DSP and FPGA with high-density, and optimized software algorithm, so this product is applied to multiple applications of vibrating mirror real-time control.

RDM4024C-PCI has sophisticated functions, and support rotating marking, flying marking, etc. Besides, there is a matched expansion interface for 4-axis motor control, which can fulfill the independent 4-axis motor interpolation motion.

1.2 Laser Vibrating Mirror Motion Controller Models and Definitions.

RDM4024C-PCI

SN	Definition
RD	Company logo
MV	M: marking control series. V: vision function
4	The 4th generation hardware platform
0	The subversion of 3rd generation hardware platform
2	Reserved
4	Support common marking, rotating marking and flying marking, extended 4-axis continuous track motion control, customized 3D automatic focusing function
G	General
PCI	PCI interface

1.3 Laser Vibrating Mirror Motion Controller Functions

Functions	RDM4024C-PCI
Vibrating Mirror Control	
interface	PCI
analog quantity output	none
digital interface output	3-way, according with XY2-100 protocol
interpolation motion	Jump, vector, scanning
external start input	1-way
external stop input	1-way
Laser Control	
Supported Laser	CO2 (RF/Glass tube), YAG and fiber laser
laser switch control	1-way, TTL level, high level valid
PWM output (Q pulse)	2-way, TTL level, high level valid
FPK signal output	1-way, TTL level, high level valid
laser control analog voltage	2-way, 0~5V, 0~10V
fiber laser special signal	8-bit power control digital output L0~L7, non-isolated 1-way LATCH signal output 1-way repetition frequency output 1-way MO 1-way GATE 1-way EMSTP (external control) 1-way GL (external control)
Motor Control	
limit signal input	4-axis, negative/positive limit for each axis, optoelectronic isolation input
HOME signal input	4-axis, one way for each axis, HOME signal input, optoelectronic isolation input
drive alarm signal input	4-axis, one way for each axis, optoelectronic isolation input
pulsed quantity output	4-way, differential output

Functions	RDM4024C-PCI
Directional signal output	4-way, differential output
General Purpose Input / Output	
general digital signal input	8-way, optoelectronic isolation input
general digital signal output	8-way, optoelectronic isolation output
Flying Marking	
encoder input	A+, A-, B+, B-input, TTL level
IO trigger	optoelectronic isolation , low level effective

1.4 Basic Components of Laser Vision Marking System

- Laser marking controller
- PC with PCI
- Industrial camera and supporting lens, illuminating system
- Laser device
- Vibrating mirror
- The related electric auxiliary

Chapter 2 Installation & Operation

2.1 List of products

When you received our product, please check the type and accessories and make sure these are what you ordered. If wrong, please contact RuiDa technology. If the model is consistent, the user can open the packing, after opening the package, because of the controller circuit board has a lot of electrostatic sensitive devices, in order to prevent the damage of electrostatic, please wear good anti-static gloves, and then carefully check whether there is any damage on the board, if there is damage, please contact the RuiDa technology.

Please take good care of packaging of general motion controller, so that at the time of repairing using its original packaging to avoid damage when return to RuiDa technology.

Laser marking controller List:

- RDM4024C-PCI controller (1pcs);
- Controller terminal (1pcs);
- 62PIN cable (1pcs)
- Instruction and CD (1pcs)
- Antistatic glove (1pcs)



Dangerous !

Avoid the controller form ESD, please release the static charge before touching the motion controller.

2.2 RDM4024C-PCI Controller Configuration

RDM4024C-PCI controller configuration as showed in Picture 2-1

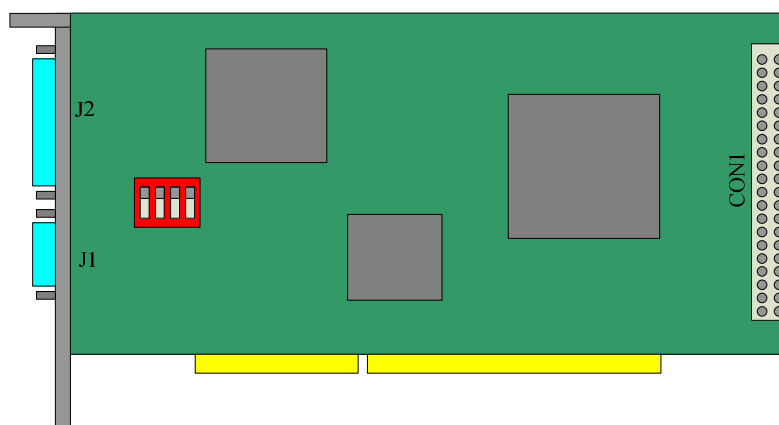

Picture 2-1

Sheet 2-1 Dial Switch SWT1 Default State

SN	STATE
1	OFF
2	OFF
3	OFF
4	OFF

Note: Dial switch is used for controller internal controlling; user cannot modify the state freely, otherwise the system cannot work normally.

J2: marking head control interface.

J1: laser control signal output interface,

CON1: extension interface

The supporting terminal structure of RDM4024C-PCI as shown in Figure 2-2:

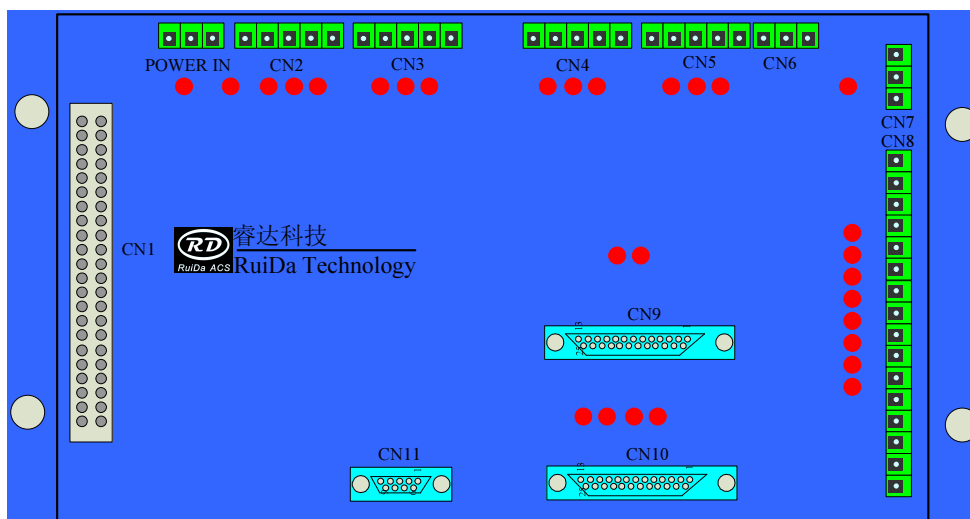

Figure 2-2

The function definition of terminals as below sheet 2-2 showed:

Sheet 2-2 Terminals Definition

Terminal	Signal Definition
CN1	master controller connector
POWER IN	power supply
CN2	dedicated IO interface of motor axis 1
CN3	dedicated IO interface of motor axis 2
CN4	dedicated IO interface of motor axis 3
CN5	dedicated IO interface of motor axis 4
CN6	flying marking trigger IO interface
CN7	fiber laser external control interface
CN8	general 16-way IO
CN9	low power fiber laser interface
CN10	motor control dedicated interface
CN11	flying marking encoder interface

2.3 System Installation & Application Steps.

Please follow the steps to establish control system as follows:

Step1: Insert the motion controller into computer



Dangerous !

To avoid the controller form ESD, please release the static charge before touching the motion controller.

- Turn off the computer power supply; ensuring pulled out the AC input plug.
- Wear anti-static gloves.
- Open the computer case, insert the laser marking controller into the slot in a reliable way.
- Tighten the retaining screw.
- Open the PC power supply, start the computer, at this time if the controller indicator on the upper left corner flashing, which means the marking card is working properly.
- Turn off the computer, disconnect the power supply.
- Connect the other control equipment to marking controller, such as laser device, laser marking head,

motor, etc.

- Open the PC power supply again, the system can work normally.

Step 2: Driver Installation

This controller is suitable for Windows XP, Windows 7, if it is other operating system, please contact Ruida technology technical support.

- After starting Windows operating system, the system will detect the PCI devices automatically, and prompted to install the driver. Choose “install from list or specified location”, then click "next".
- On this page, select "search the best driver in these positions", and select the "include the position in the search", click on the "browse", enter into the file selection interface.
- Put the CD including product drive program into CD driver.
- Using "browse" to choose "cd-rom: \ Window XP \ DRIVERS \ PCI" under the corresponding operating system directory.
- To follow “add hardware guide ", click" next ", until done.
- Check “device properties” in the computer system at this time, there will be new equipment "RDDriver". Click "+", displaying "RuiDa Tech RD400SCAN Ver 1.0"

Step 3: Marking controller running test

First, observe the indicator light is flashing normally, if failed, please contact Ruida technology. Secondly, confirm PCI driver installed correctly, and then open the application software for controller and PCI communication test, and operate as the software instruction. If needed, please contact us.

Step 4: Connect laser marking controller and motor control extended terminal

If the user does not need extended terminal, then insert the controller into PCI slot of computer directly. If need motor terminal, you may need to connect the controller and extended terminal through PIN 62 cable.

Step 5: Connect vibrating mirror and laser

1. J2--The vibrating mirror interface connection

Before connecting, you must know the marking head interface standard, firstly, to determine the marking head interface is digital or analog. If digital interface and satisfied the XY2-100 communication protocol, so the it can direct connect to J2 terminal of controller. If the marking head is analog, so it must connect via XY2-100 DA terminal. RDM4024C_PCI only supports XY2-100 digital interface.



Note

For safety's sake, it is recommended that the user uses the controller initially; you must read this manual and other electrical products specifications to prevent the unmatched power supply, and short circuit, etc.

The terminal interface J2 of controller is the marking head interface, J2 is the female of DB25, vibrating mirror connects to master controller by J2, J2 can connect directly to digital (according with XY2-100 protocol) mirror and analog vibrating mirror. Signal is defined as shown in sheet 2-3.

Sheet 2-3 J2 Signal Definition

PIN	Definition	Description
1	CLOCK-	XY2-100 protocol clock signal negative terminal
2	SYNC-	XY2-100 protocol synchronizing signal negative terminal
3	CHAN1-	XY2-100 protocol data signal negative terminal
4	CHAN2-	XY2-100 protocol data signal negative terminal
5	CHAN3-	XY2-100 protocol data signal negative terminal
6	STS-	XY2-100 protocol state feedback signal negative terminal
7	NC	XY2-100 protocol clock signal negative terminal
8	NC	
9	NC	
10	NC	
11	GND	GND
12	NC	
13	NC	
14	CLOCK+	XY2-100 protocol clock signal positive terminal
15	SYNC+	XY2-100 protocol synchronizing signal positive terminal
16	CHAN1+	XY2-100 protocol the first data positive terminal
17	CHAN2+	XY2-100 protocol the second data positive terminal
18	CHAN3+	XY2-100 protocol the third data positive terminal
19	STS+	
20	NC	
21	NC	
22	NC	
23	GND	GND
24	GND	GND
25	NC	

2. J1--The laser interface connection

J1 interface of controller is female DB9, a standard laser control interface, supported CO2 laser and YAG laser, if using fiber laser, so choose the fiber extended interface. J1 provides all the control signals which applied to the two kinds of laser. J1 signal is defined as shown in Sheet 2-4.

Sheet 2-4 J1 Signal Definition

PIN	Definition	Description
1	PWM1	PWM output (or repetition frequency output)
2	LASERON	Laser switching signal output
3	PWM2	The second PWM (FPS) output
4	VCC	+5V power output
5	GND	GND
6	DA1	The first analog output
7	DA2	The second analog output
8	/START	External start signal input
9	/STOP	External stop signal input

Note

For safety's sake, it is recommended that the user uses the controller initially; you must read this manual and other electrical products specifications to prevent the unmatched power supply, and short circuit, etc.

J1 interface signal output is suitable for CO2 (glass tube/RF) laser, YAG laser. So the output signal is reused, which can be set by software. After setting, the signal definition as below:

Sheet 2-5 Signal Output Setting

PIN	Definition	CO2 RF Tube	CO2 Glass Tube	YAG Mode
1	PWM1	The first power control PWM output	NC	Repetition frequency output
2	LASERON	NC	LASERON	Laser switching signal
3	PWM2	The second power control output	NC	FPS output
8	ANALOG1	NC	NC	Modulation frequency control
3	ANALOG2	NC	ANALOG1 power regulation analog output	Power current control



Note

When connecting with machine, you must pay attention to the system sequence of power-on: firstly, open the computer power supply; secondly, open the device power supply due to the controller has a initialization process, maybe cause the laser control signal is out of control, the laser will be emitted.

2.4 Terminal

As showed below, terminal provides 4 motor control signals, fiber laser control interface, flying marking interface, and general I/O interface.

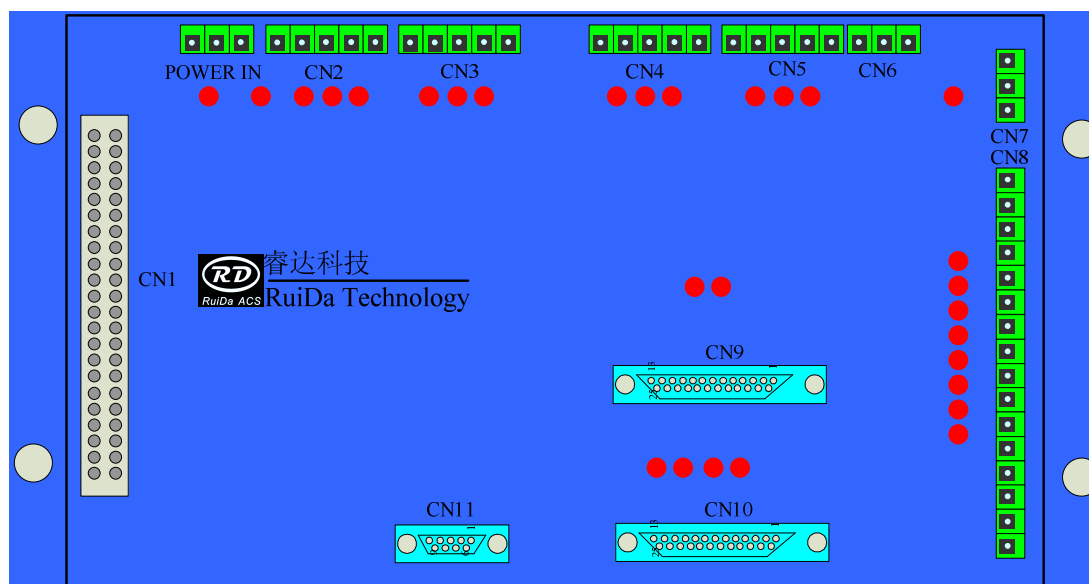

Picture2-3 terminal

The interfaces definition of terminal as sheet 2-6:

Sheet 2-6 Interfaces Definition

Terminals	Definition	Description
CN1	Master controller terminal	Connect to PCI, 62 PIN DB terminal
POWER IN	Power supply	24V power supply
CN2	Motor 1 special signal interface	HOME switch and limit switch input
CN3	Motor 2 special signal interface	HOME switch and limit switch input
CN4	Motor 3 special signal interface	HOME switch and limit switch input
CN5	Motor 4 special signal interface	HOME switch and limit switch input
CN6	Flying trigger IO input	Optoelectronic isolation input, 24V standard
CN7	Fiber laser external control	Low power fiber laser external control input, including emergence stop input and lead laser input

CN8	General I/O interface	8-way general input, 8-way general output
CN9	Low power fiber laser control special interface	
CN10	Motor control interface	Output PULSE+DIR or +/-PULSE
CN11	Flying encoder input interface	A+, A-, B+, B-. TTL level input

The detailed definition of POWER IN internal signal as showed in sheet 2-7.

Sheet 2-7 POWER IN Terminal Definition

PIN	Definition	Description
1	OVCC	24V power supply input
2	OGND	GND
3	PGND	PGND

The detailed signal definition of CN2, CN3, CN4, CN5 showed in sheet 2-8. Schematic circuit diagram as Picture 2-4:

Sheet 2-8 CN2/CN3/CN4/CN5 Terminal Definition

PIN	Definition	Description
1	OVCC	24V power supply output
2	LMT-	motor axis negative limit signal input
3	HOME	motor axis HOME signal input
4	LMT+	motor axis positive limit signal input
5	OGND	GND

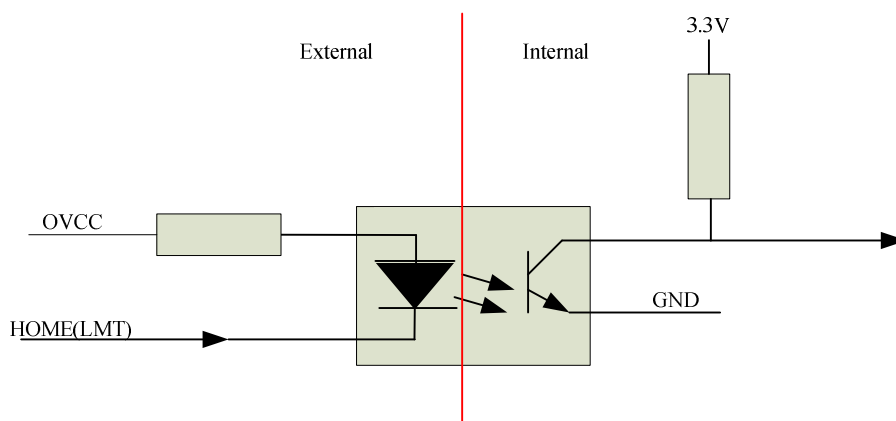

Picture 2-4 Schematic circuit diagram

The signal definition of CN6 interface as sheet 2-9 showed:

Sheet 2-9 CN6 Terminal Definition

PIN	Definition	Description
1	OVCC	24V power output
2	TRIG	external trigger signal input
3	OGND	GND

The interface circuit of trigger signal as Picture 2-5 showed. The trigger signal can be mechanical switch or optoelectronic switch or inductive switch.

If mechanical switch, the one end connects to OGND, the other end connects to TRIG input end. If optoelectronic switch or inductive switch, choose NPN output switch, power supply using OVCC and OGND, the switch output connects to TRIG output end.

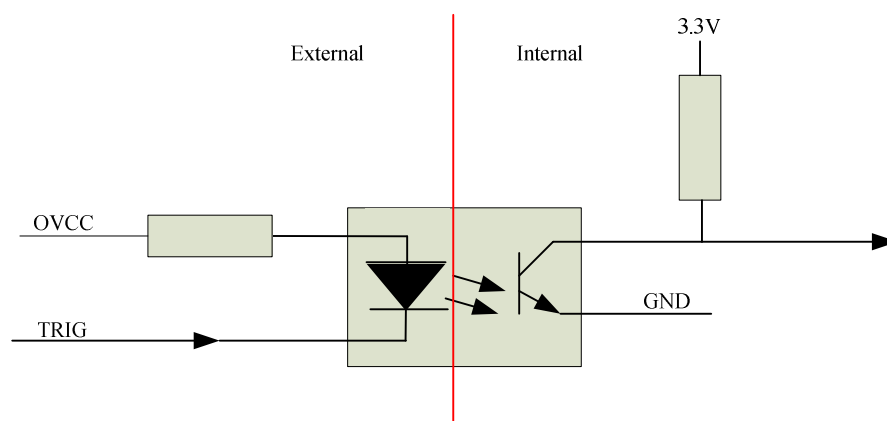

Picture 2-5 Flying trigger signal schematic diagram

The signal definition of CN7 interface as sheet 2-10 showed:

Sheet 2-10 CN7 I/O interfaces

PIN	Definition	Description
1	EMSTP	external switch directly control fiber laser off (P9)
2	GND	GND
3	GL	external switch directly control guide fiber laser (P10)

Note: The guide laser of fiber laser and emergency stop can be controlled by internal control (software

control) and external control (external switch).

If external switch control, the terminal jumper wire should be set properly as below:

	Terminal P9	Terminal P10	Function
PIN	1-2	1-2	external switch control
PIN	2-3	2-3	internal software control

The signal definition of CN8 interface as sheet 2-11 showed:

Sheet 2-11 CN8 I/O Interfaces

PIN	Definition	Descriptions
1	OUT0	general output, optoelectronic isolation Darlington output, 24V standard, can drive relay
2	OUT1	general output, optoelectronic isolation Darlington output, 24V standard, can drive relay
3	OUT2	general output, optoelectronic isolation Darlington output, 24V standard, can drive relay
4	OUT3	general output, optoelectronic isolation Darlington output, 24V standard, can drive relay
5	OUT4	general output, optoelectronic isolation Darlington output, 24V standard, can drive relay
6	OUT5	general output, optoelectronic isolation Darlington output, 24V standard, can drive relay
7	OUT6	general output, optoelectronic isolation Darlington output, 24V standard, can drive relay
8	OUT7	general output, optoelectronic isolation Darlington output, 24V standard, can drive relay
9	IN0	general input, optoelectronic isolation,24V standard
10	IN1	general input, optoelectronic isolation,24V standard
11	IN2	general input, optoelectronic isolation,24V standard
12	IN3	general input, optoelectronic isolation,24V standard
13	IN4	general input, optoelectronic isolation,24V standard
14	IN5	general input, optoelectronic isolation,24V standard
15	IN6	general input, optoelectronic isolation,24V standard
16	IN7	general input, optoelectronic isolation,24V standard

The circuit diagram of general I/O as picture 2-6.2-7 showed:

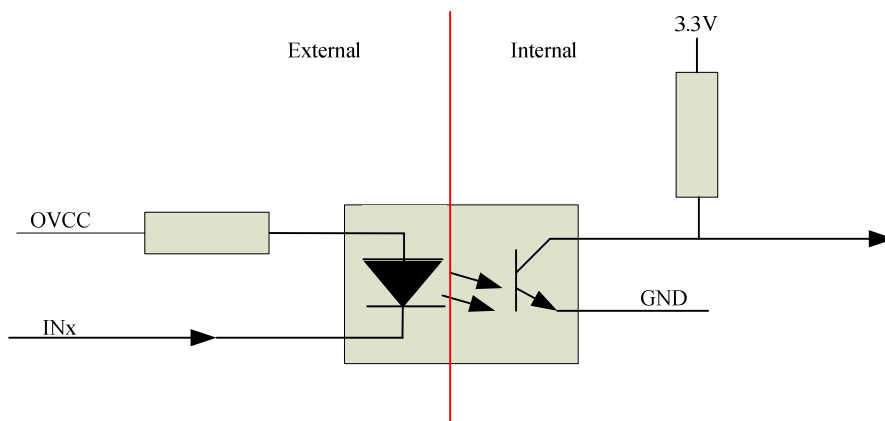

Picture 2-6 General Input Circuit Diagram

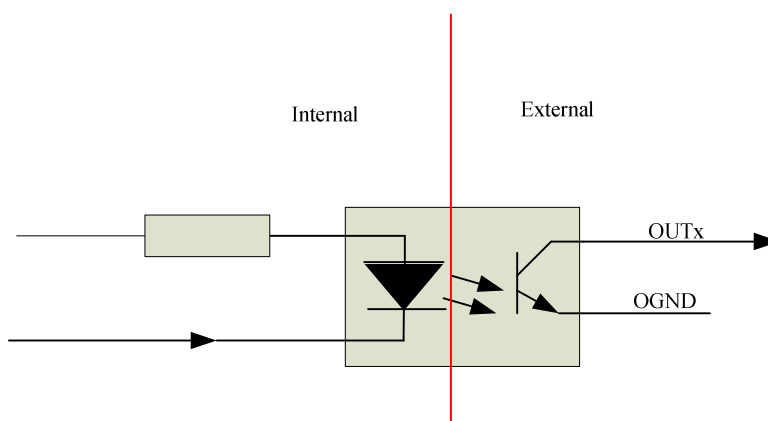

Picture 2-7 General Output Circuit Diagram

The signal definition of CN9 interface as sheet 2-12 showed:

Sheet 2-12 CN9 fiber laser interfaces

PIN	Signal Definition	Description
1	L0	BIT0 digital quantity output
2	L1	BIT1 digital quantity output
3	L2	BIT2 digital quantity output
4	L3	BIT3 digital quantity output

5	L4	BIT4 digital quantity output
6	L5	BIT5 digital quantity output
7	L6	BIT6 digital quantity output
8	L7	BIT7 digital quantity output
9	latch	power LATCH signal
10	GND	digital GND
11	GND	digital GND
12	GND	digital GND
13	GND	digital GND
14	GND	digital GND
15	GND	digital GND
16	FAULT1	laser fault output
17	NC	
18	MO	master oscillator signal
19	LASERON	laser gating signal
20	PPR	repetition frequency
21	FAULT	laser fault output
22	GL	guide laser control output
23	EMSTP	emergency stop output
24	GND	digital GND
25	NC	

The signal definition of CN10 interface as sheet 2-13 showed:

Sheet 2-13 CN10 Motor Interfaces

PIN	Signal Definition	Description
1	OGND	External GND
2	ALM0	axis-1 alarm input
3	PULSE0+	axis-1 pulse signal positive terminal
4	PULSE0-	axis-1 pulse signal negative terminal
5	DIR0+	axis-1 direction signal positive terminal
6	DIR0-	axis-1 direction signal negative terminal
7	+5V	+5V output
8	ALM1	axis-2 alarm input
9	PULSE1+	axis-2 pulse signal positive terminal
10	PULSE1-	axis-2 pulse signal negative terminal

11	DIR1+	axis-2 direction signal positive terminal
12	DIR1-	axis-2 direction signal negative terminal
13	GND	digital GND
14	OVCC	external 24V power supply output
15	ALM2	axis-3 alarm input
16	PULSE2+	axis-3 pulse signal positive terminal
17	PULSE2-	axis-3 pulse signal negative terminal
18	DIR2+	axis-3 direction signal positive terminal
19	DIR2-	axis-3 direction signal negative terminal
20	ALM3	axis-4 alarm input
21	PULSE3+	axis-4 pulse signal positive terminal
22	PULSE3-	axis-4 pulse signal negative terminal
23	DIR3+	axis-4 direction signal positive terminal
24	DIR3-	axis-4 direction signal negative terminal
25	NC	

The signal definition of CN11 interface as sheet 2-14 showed:

Sheet 2-14 CN11Flying encoder input interface

PIN	Signal Definition	Description
1	VCC	+5V power output
2	A0+	encoder A+
3	B0+	encoder B+
4	NC	
5	GND	digital GND
6	A0-	encoder A-
7	B0-	encoder B-
8	NC	
9	NC	

● **CN9 Fiber laser interface (IPG-YLP series laser connection):**

RDM4024C-PCI provides a group special signals for controlling, the signal definition as Sheet 2-15 showed. The L0~L7 is 8-digital quantity output. EX_OUT0, EX_OUT is two-way auxiliary IO outputs. LATCH is 8-digital latch signal; MO is fiber laser master oscillator enable signal. This interface only is effective when calling software setting as “fiber laser” mode.

Note: This interface and controller is common ground, without optoelectronic isolation!

Sheet 2-15 CN9 Fiber laser interface

PIN	Signal Definition	Description
1	L0	BIT0 digital quantity output
2	L1	BIT1 digital quantity output
3	L2	BIT2 digital quantity output
4	L3	BIT3 digital quantity output
5	L4	BIT4 digital quantity output
6	L5	BIT5 digital quantity output
7	L6	BIT6 digital quantity output
8	L7	BIT7 digital quantity output
9	latch	power latch signal
10	GND	digital GND
11	GND	digital GND
12	GND	digital GND
13	GND	digital GND
14	GND	digital GND
15	GND	digital GND
16	FAULT1	laser fault output
17	NC	
18	MO	master oscillator signal
19	LASERON	laser gating signal
20	PPR	repetition frequency
21	FAULT	laser fault output
22	GL	guide laser control output

23	EMSTP	emergency stop output
24	GND	digital GND
25	NC	

The interface signal of controller and YLP series as sheet 2-16 showed

Sheet 2-16 IPG- YLP Laser Wiring
(use one-to-one DP25 interface cable)

IPG-YLP		RDM4024C-PCI	
PIN	Definition	PIN	Definition
PIN1~8	laser power setting digital quantity	PIN1~8	8-digital digital quantity output
PIN9	power latch signal	PIN9	digital quantity latch signal output (*****)
PIN17	Guide laser input (when no need guide laser, this pin is NC.)	PIN17	+5V power output (*)
PIN18	MO control signal	PIN18	Single IO output (**)
PIN19	modulation control input terminal	PIN19	GATE output signal
PIN20	repetition frequency input terminal	PIN20	PWM output signal
PIN22	Emergency stop input terminal	PIN22	Single IO output(***)
PIN23	guide laser control input terminal	PIN23	Single IO output (****)

- * The max. output of the pin is 0.8A, please pay attention to the output driver ability!
- ** MO control signal, rising edge effective, ensure the pin initial low level, then set to high level!
- *** Laser inhibit control, low level effective! User laser emergency stop control.
Set high level effective is a must when working normally.
- **** Guide laser control, high level effective! At this time, laser PIN19 function is prohibited; the details please refer to IPG-YLP operation manual.
- ***** The sequential relationship of LATCH signal and 8-digital quantity as below:



- XY2-100 dedicated connecting line making instruction
Through controller digital output connector (DB25-FEMALE) connecting with digital marking head, the internal twisted pair & external shield cable is a must.

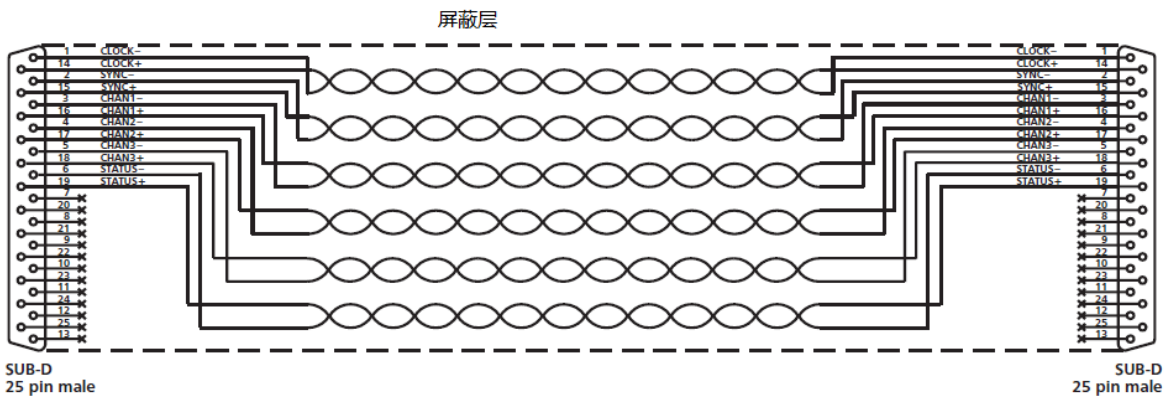

Note: the length of connecting line cannot more than 10m.



Thank you very much for using the product from Shenzhen RuiDa Technology!

All parts of this manual description, all rights reserved by Shenzhen RuiDa Technology Co., Ltd. Without our permission, any company or individual shall not reprint, copy or distribute the content related to this product manual. We keep the rights to revise or update the contents without Note.

If any comments and suggestions please feel free to contact us.

Phone: 0755-26066687 Fax: 0755-26982287

Website: www.rd-ac.com

Address: 1B-1, Building 5, Tian'an Nanyou Industry Area,
Dengliang Road, Nanshan District, Shenzhen, P.R.C.